



compac

PREMIUM DISPENSER TECHNOLOGY

Master C5000 MMA30-160S Dispenser Installation Manual

Version No 1.0.0

Model: MMA30-160S

Date: 11th December 2023



Conditions of Use

- Read this manual completely before working on, or making adjustments to, the Compac equipment
- Compac Industries Limited accepts no liability for personal injury or property damage resulting from working on or adjusting the equipment incorrectly or without authorization.
- Along with any warnings, instructions, and procedures in this manual, you should also observe any other common sense procedures that are generally applicable to equipment of this type.
- Failure to comply with any warnings, instructions, procedures, or any other common sense procedures may result in injury, equipment damage, property damage, or poor performance of the Compac equipment
- The major hazard involved with operating the Compac C5000 processor is electrical shock. This hazard can be avoided if you adhere to the procedures in this manual and exercise all due care.
- Compac Industries Limited accepts no liability for direct, indirect, incidental, special, or consequential damages resulting from failure to follow any warnings, instructions, and procedures in this manual, or any other common sense procedures generally applicable to equipment of this type. The foregoing limitation extends to damages to person or property caused by the Compac C5000 processor, or damages resulting from the inability to use the Compac C5000 processor, including loss of profits, loss of products, loss of power supply, the cost of arranging an alternative power supply, and loss of time, whether incurred by the user or their employees, the installer, the commissioner, a service technician, or any third party.
- Compac Industries Limited reserves the right to change the specifications of its products or the information in this manual without necessarily notifying its users.
- Variations in installation and operating conditions may affect the Compac C5000 processor's performance. Compac Industries Limited has no control over each installation's unique operating environment. Hence, Compac Industries Limited makes no representations or warranties concerning the performance of the Compac C5000 processor under the actual operating conditions prevailing at the installation. A technical expert of your choosing should validate all operating parameters for each application.
- Compac Industries Limited has made every effort to explain all servicing procedures, warnings, and safety precautions as clearly and completely as possible. However, due to the range of operating environments, it is not possible to anticipate every issue that may arise. This manual is intended to provide general guidance. For specific guidance and technical support, contact your authorised Compac supplier, using the contact details in the Product Identification section.
- Only parts supplied by or approved by Compac may be used and no unauthorised modifications to the hardware or software may be made. The use of non-approved parts or modifications will void all warranties and approvals. The use of non-approved parts or modifications may also constitute a safety hazard.
- Information in this manual shall not be deemed a warranty, representation, or guarantee. For warranty provisions applicable to the Compac C5000 processor, please refer to the warranty provided by the supplier.
- Unless otherwise noted, references to brand names, product names, or trademarks constitute the intellectual property of the owner thereof. Subject to your right to use the Compac C5000 processor, Compac does not convey any right, title, or interest in its intellectual property, including and without limitation, its patents, copyrights, and know-how.
- Every effort has been made to ensure the accuracy of this document. However, it may contain technical inaccuracies or typographical errors. Compac Industries Limited assumes no responsibility for and disclaims all liability of such inaccuracies, errors, or omissions in this publication.

Product Identification

Specifications

Models Covered

This manual applies to the Master C5000 MMA30-160S Dispenser

NOTE: Do not use this manual for earlier models. Contact Compac for archived manuals if required.

Validity

Compac Industries Limited reserves the right to revise or change product specifications at any time. This publication describes the state of the product at the time of publication and may not always reflect the product in the past or in the future.

CONDITIONS

Manufactured By:

The Compac MMA30-160S Dispenser is designed and manufactured by Compac Industries Limited

52 Walls Road, Penrose, Auckland 1061, New Zealand

P.O. Box 12-417, Penrose, Auckland 1641, New Zealand

Phone: + 64 9 579 2094

Fax: + 64 9 579 0635

Email: techsupport@compac.co.nz

www.compac.biz

Copyright ©2015 Compac Industries Limited, All Rights Reserved



Document Control

Document Information	
Manual Title	Master C5000 MMA30-160S Dispenser Installation Manual
Current Revision Author(s)	Trevor Watt
Original Publication Date	11/12/2023
Authorised By	Emily Sione

Revision History			
Version	Date	Author(s)	Revision Notes
1.0.0	11/12/2023	T Watt	New Installation Manual specifically for this model

Contents

Product Identification	3
Footprints	4
MMA30-160S Footprint	4
Installation	6
Precautions	6
Pre-Installation Check	6
Procedures	6
Hoses and Nozzles	7
Breakaways	7
Pump Specifications	7
Typical Wiring	8
Incoming Mains	9
Comms Connections	10
K-Factor Board	11
Terminal Board Connections	12
Setting up the C5000	13
K-Factor Settings	13
Submersible Delay (Sd)	14
Parameter Settings	15
AdBlue Instructions	17
Cleaning the AdBlue Nozzle	17
ZVA AdBlue Nozzle	17
Notes	18
Pump Controller	18
Spare Fuses	18
Precautions if Using Generator Power	18
Error Messages	19

Product Identification

Ensure you are using the correct installation instructions and footprint drawing before commencing site work or installation.

The identification plate is fastened to the bottom of the right-hand side panel when facing the front of the dispenser.

The model number is on the first line of the identification plate.

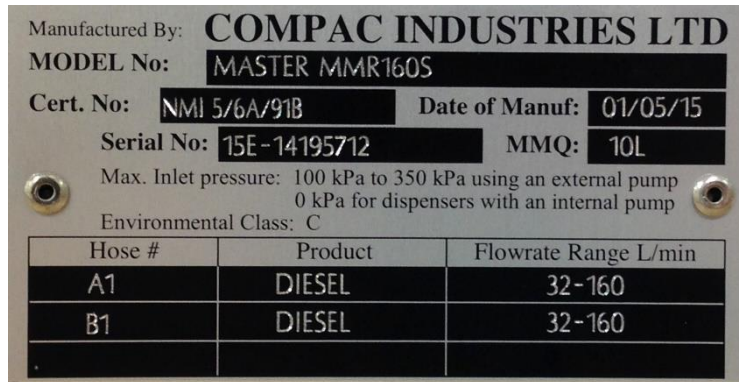

Understanding the Model Number:

The model number for Master dispensers is split into: Chassis style, hose configuration, pump or dispenser and specific application.

Use the table below to help identify the unit.

Style	L/min per hose	Pump style	Options
MR = single hose	MR40 = one hose @ 40 l/min	P = pump	Blank = Standard
MMR = multi hose	MMR40 = two hoses @ 40 l/min	S = dispenser	Avi = Aviation
	MMR80-40 = side A 80, side B 40		Marine = Marine

For example: MMR 80-40S Marine is a two-hose unit. Hose side A is 80 l/min, side B is 40 l/min with external pumps.

NOTE: Marine and aviation models have stainless steel pipework and stainless-steel chassis.

NOTE: Make sure you use the footprint that relates exactly to your model.

Footprints

Outlet sizes: 80 l/min 1", 160 l/min 1 ¼", 400 l/min 2" female BSP socket

NOTE: Make sure the footprint you use matches the dispenser model you are installing. Standard, marine and aviation footprints are common unless otherwise stated.

NOTE: Marine and aviation dispensers use stainless steel pipework.

* NOTE: The footprint will be rotated 180° on a unit that has the Hoses "reversed".

Approved for Manufacture:

Signed / Date:

Title:

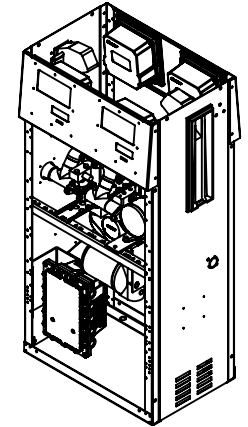
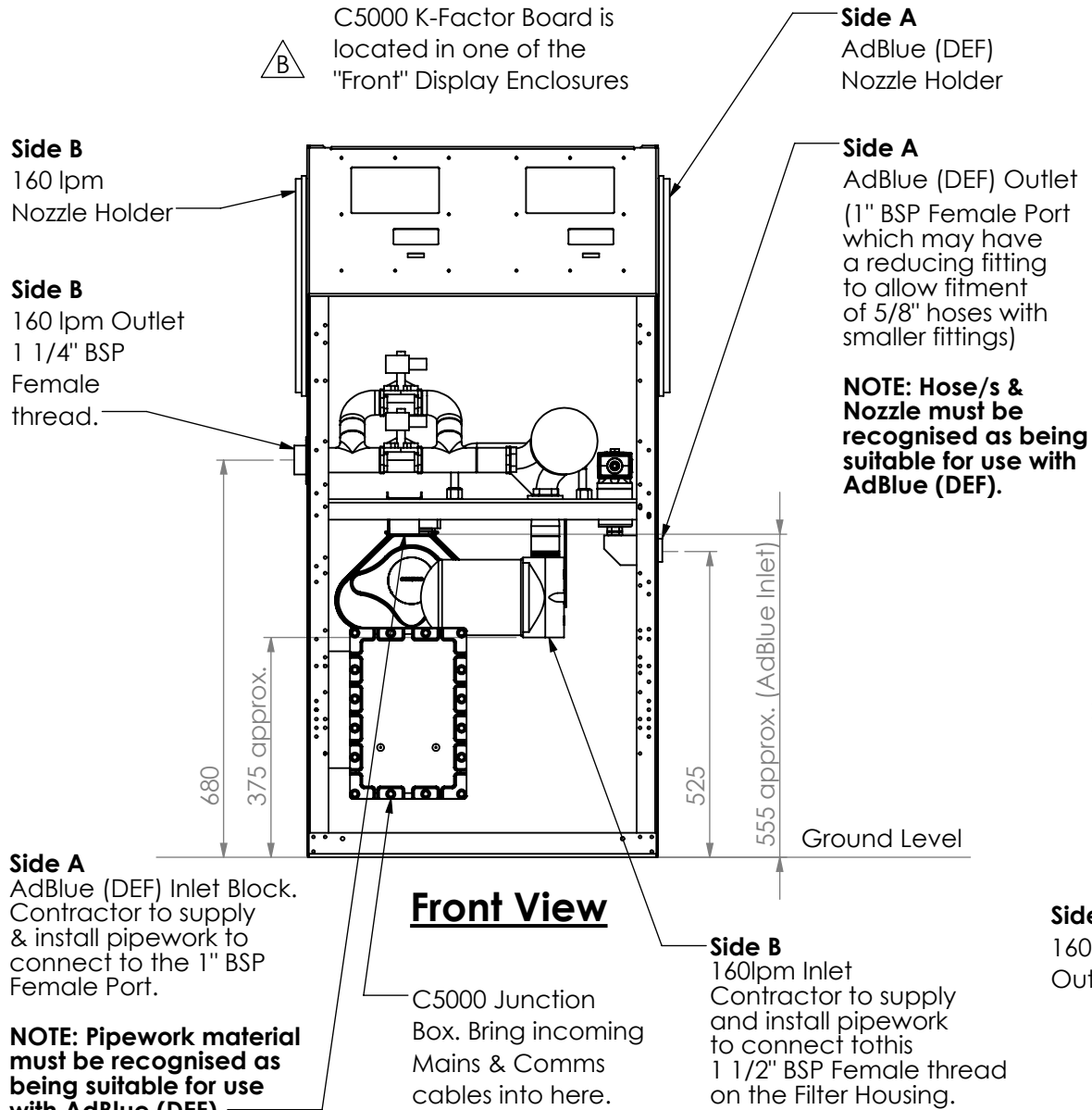

Rear of Unit

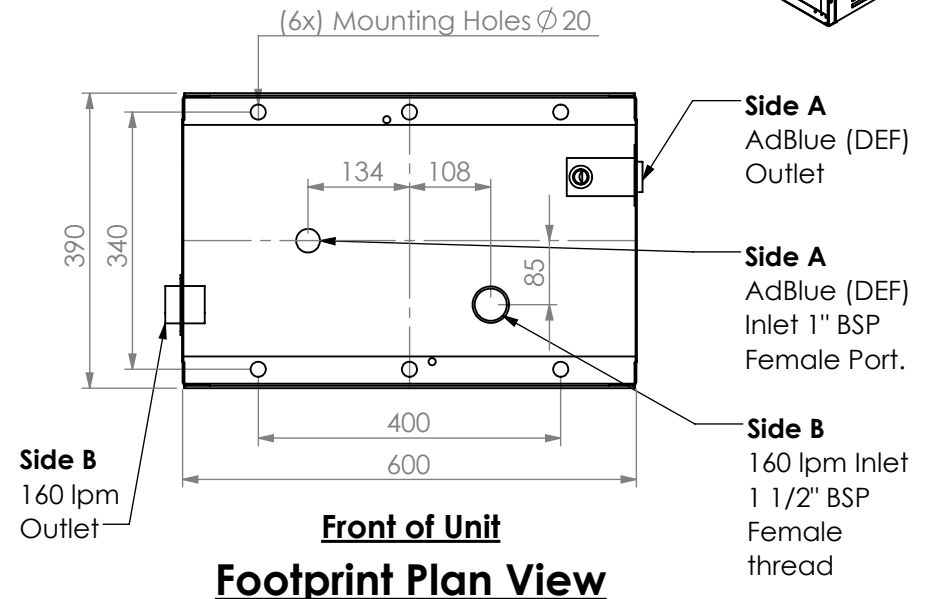

Date: 7/11/2019

Revision Description: Amend "K-Factor Board" Note



© Copyright
Compac Industries Ltd
PO Box 12-417
52 Walls Road
Penrose, Auckland, NZ
Ph 649 5792094
Fax 649 5790635

General Tolerances
All dimensions millimetres

Remove all burrs
and sharp edges.
Original Size A4.
Do not scale
from drawing.



**Master PN4 MMA30-160S AdBlue (DEF)
Dispenser Footprint Drawing**

Drawing
MAD0135B

Sheet
1/1

Part Revision
A

Installation

Precautions

Electronic components used are sensitive to static. Please take anti-static precautions. An anti-static wrist strap should be worn and connected correctly when working on any electronic equipment. If an anti-static wrist strap is unavailable, or in an emergency, hold onto an earthed part of the pump/dispenser frame whilst working on the equipment. This is not a recommended alternative to wearing an anti-static wrist strap.

NOTE: *Compac Industries Limited reserves the right to refuse to accept any circuit boards returned, if proper anti-static precautions have not been taken.*

Pre-Installation Check

Once the pump is received on site, check that no damage has occurred while in transit – in particular, damage to electronics due to vibration or jarring. All terminals and plugs should be checked, including IC chips, to ensure they are securely in place.

Procedures

Installation should be in accordance with local regulations. The dispensing equipment shall be installed to prevent the delivery hose from contacting the ground when not in use.

Care must be taken when installing pipework to make sure no oil or other contaminants enter the AdBlue lines. Do not use lubricant or thread sealing compounds on AdBlue fittings unless approved for use with AdBlue.

AdBlue is corrosive to aluminium and mild steel. All pipework and fittings that carry AdBlue must be approved for use with it.

While AdBlue is considered non-toxic, it is slightly alkaline. Protect skin and eyes from contact. Flush with water if exposed. Refer to the AdBlue MSDS for further information.

Where local regulations require a sump to be fitted:

- Sumps must be provided at all dispenser installations with secondary containment pipework and at all new installations.
- At all sites with sumps, dispensers must be installed with a liquid level detection device fitted in the sump that will raise an alarm if liquid is detected in the base of the sump.
- All Compac Master dispensers at automotive sites must have a safe break device installed in the delivery hose.
- External pump systems required to have an automatic emergency shut-off device installed at the base of each dispenser and it must be activated if the dispenser is knocked over or pulled from its mount.

Hoses and Nozzles

The unit may or may not be supplied with dispensing hose and nozzle assemblies. If customer supplied hose assemblies, pylons, reels, safe breaks and nozzles are used they must comply with the requirements outlined in AS/NZS 2229.

All dispenser nozzles must trip shut when returned to the nozzle holder.

All hoses, nozzles and fittings that come in contact with AdBlue must be compatible with it.

Breakaways

For all dispensers fitted with breakaways, ensure the breakaway is installed between the nozzle and the high-mast or pylon (if fitted). Any breakaways that have been subject to a break-away situation should be inspected and refitted or replaced in accordance with the original manufacturer's instructions.

Pump Specifications

The AdBlue supply pump must be AdBlue compatible. It must either have flooded suction or be fitted with an air separation device to eliminate air prior to the dispenser.

Ensure the supply pump pressure does not exceed the rated pressure of the nozzle.

Refer to the diagram below:

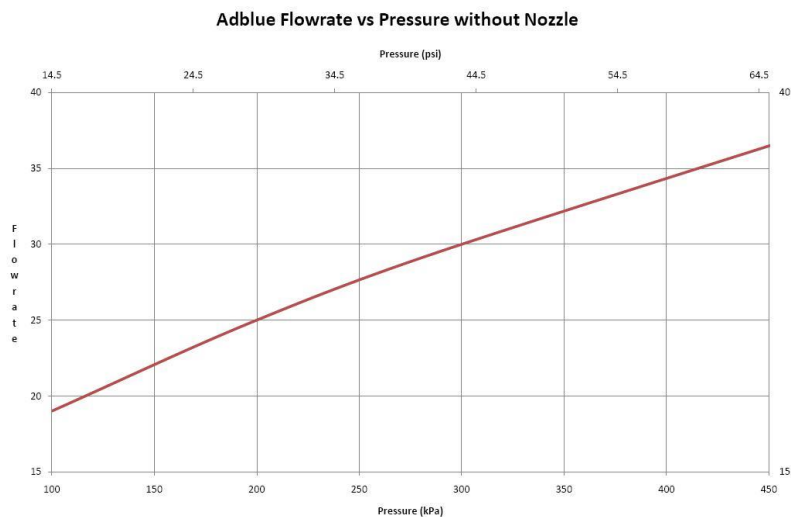

NOTE: Pumps must be rated for AdBlue.

Typical Wiring

The instructions below refer to basic installation wiring. Prior to pump installation ensure that there is at least a two-metre tail on both the incoming underground mains supply cable and comms cable (if comms enabled). These cables are terminated at the C5000 power supply, which is housed in the flameproof enclosure located in the bottom of the pump, behind the door.

Mains power wiring should be rated for a maximum current draw of 10 A rms at 220-240 V ac. Refer to AS/NZS 60079.14 for appropriate cabling.

NOTE: All cables entering the power supply must be glanded with certified 20mm flameproof glands.

NOTE: Output to submersible pump(s) is 230 V ac, 300 mA max. It is wired to the pump contactor/relay at the switchboard and not directly to the pump.

NOTE: Comms cable is not intrinsically safe.

NOTE: Pump comms connects to pump controller such as DCA, Communicator Controller etc. (option).

When replacing the lid of the flameproof enclosure, ensure the sealing O ring is in place.

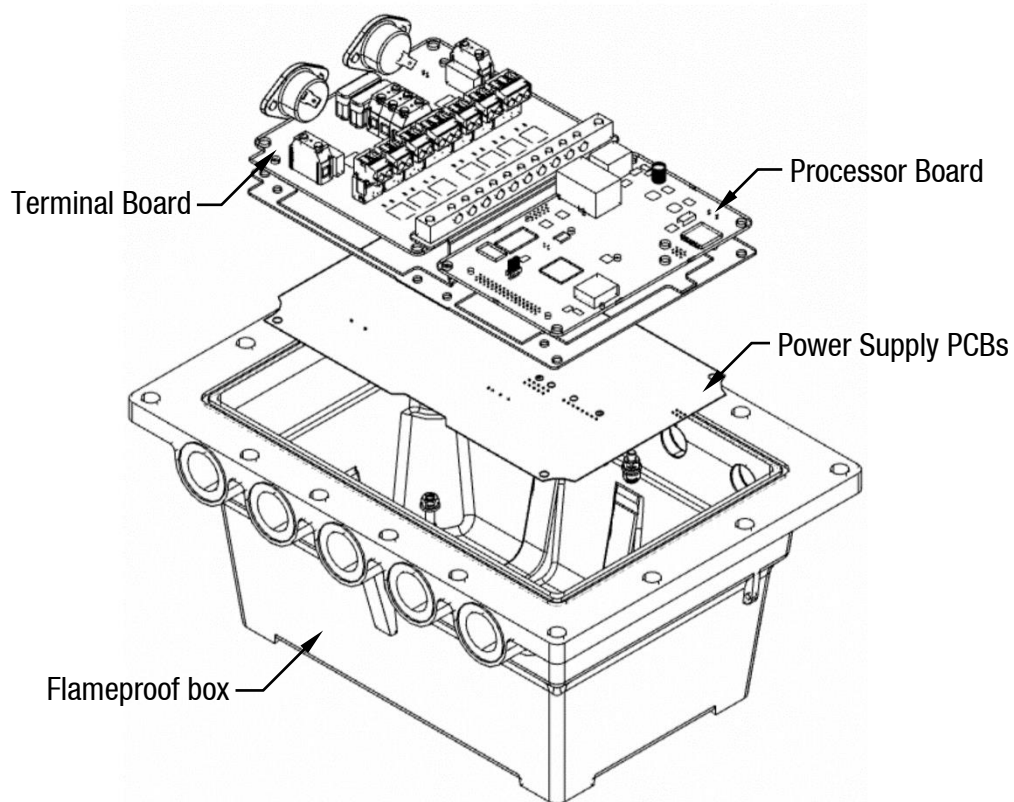

Incoming Mains

Incoming mains connections should be brought into the terminal board.

If an emergency stop button was ordered with the dispenser it will be factory wired into the terminal board, shown below. This will be in place of the normal loop between the triac and main phases.

Wires have standard colours which are shown. In case these colours are unclear, they are as follows:

- Incoming mains phase: Brown
- Incoming mains neutral: Blue
- Incoming mains earth: Green/Yellow

Refer to Terminal Board Connections on page 12 for External Pump Contactor connections

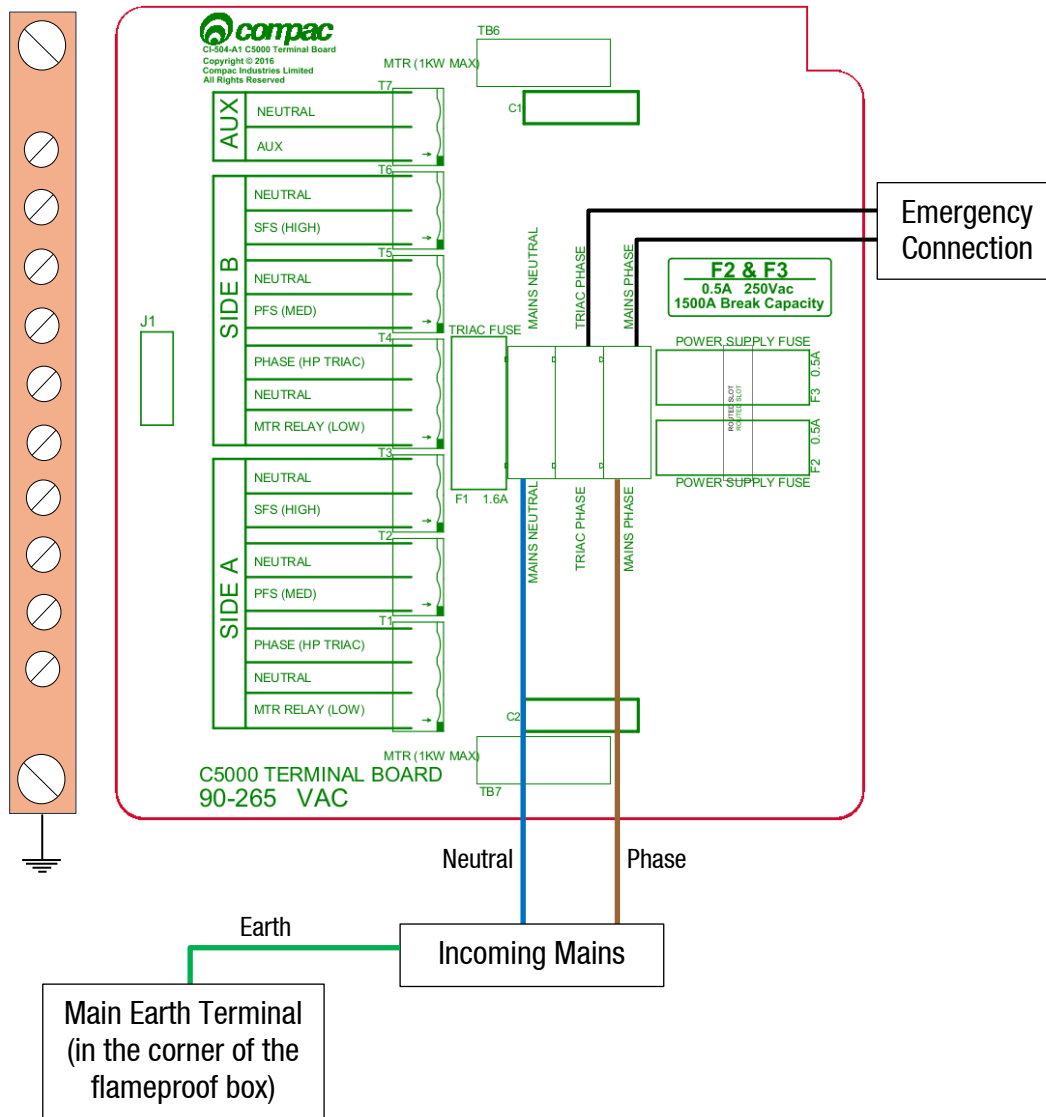

Comms Connections

The comms I/O is controlled by the connections to the Comms board. Refer to the following diagram for connecting RS485, RS232, Compac or Gilbarco pumps. The shown switch should be set to the desired setting.

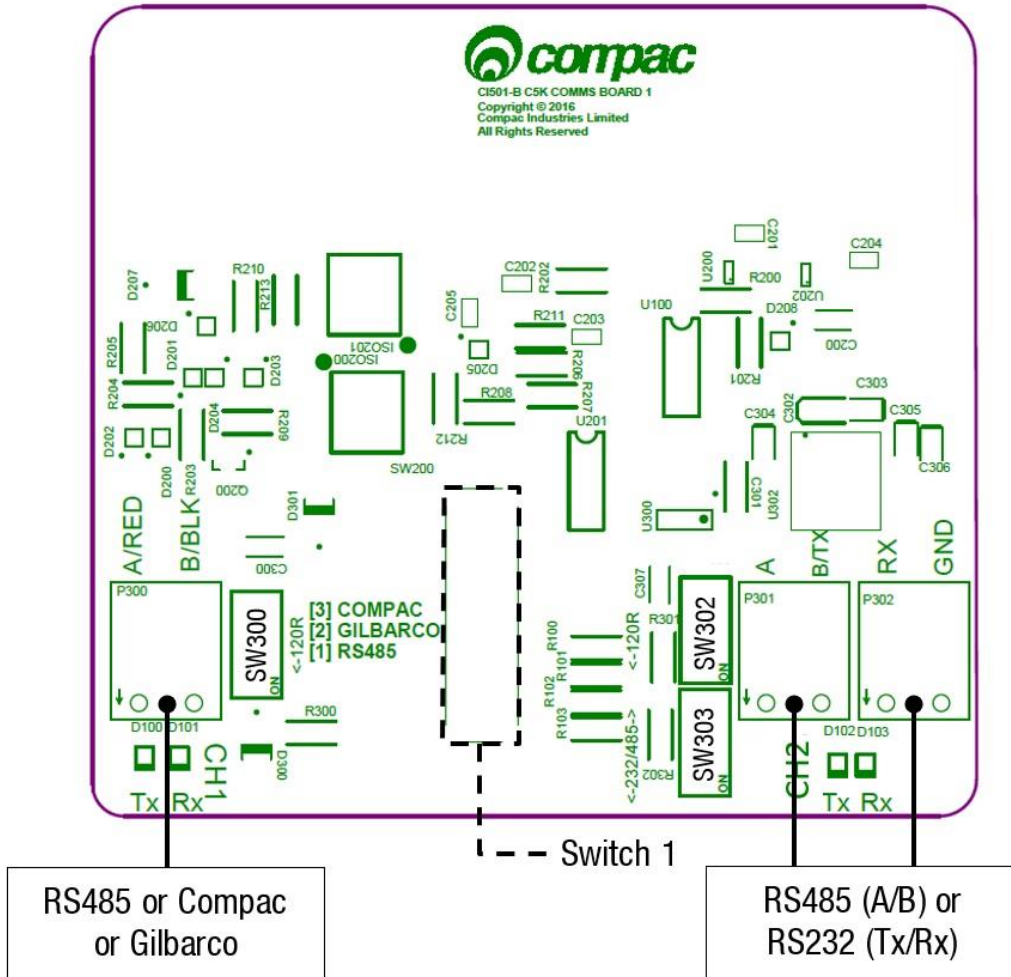

Typical Wiring

Switches 300, 302, and 303 are for RS485/RS232 Terminator application. Use the following table to configure these switches. Switch 300 is for channel 1, and switches 302 and 303 are for channel 2.

	SW300	SW302	SW303
RS485 (Channel 1)	ON	-	-
RS485 (Channel 2)	-	ON	OFF
RS232 (Channel 2)	-	OFF	ON

K-Factor Board

Both the Parameter switch and K-Factor switch are found on the K-Factor board. Meters and air switches are also connected to this board. See below for the location of these.

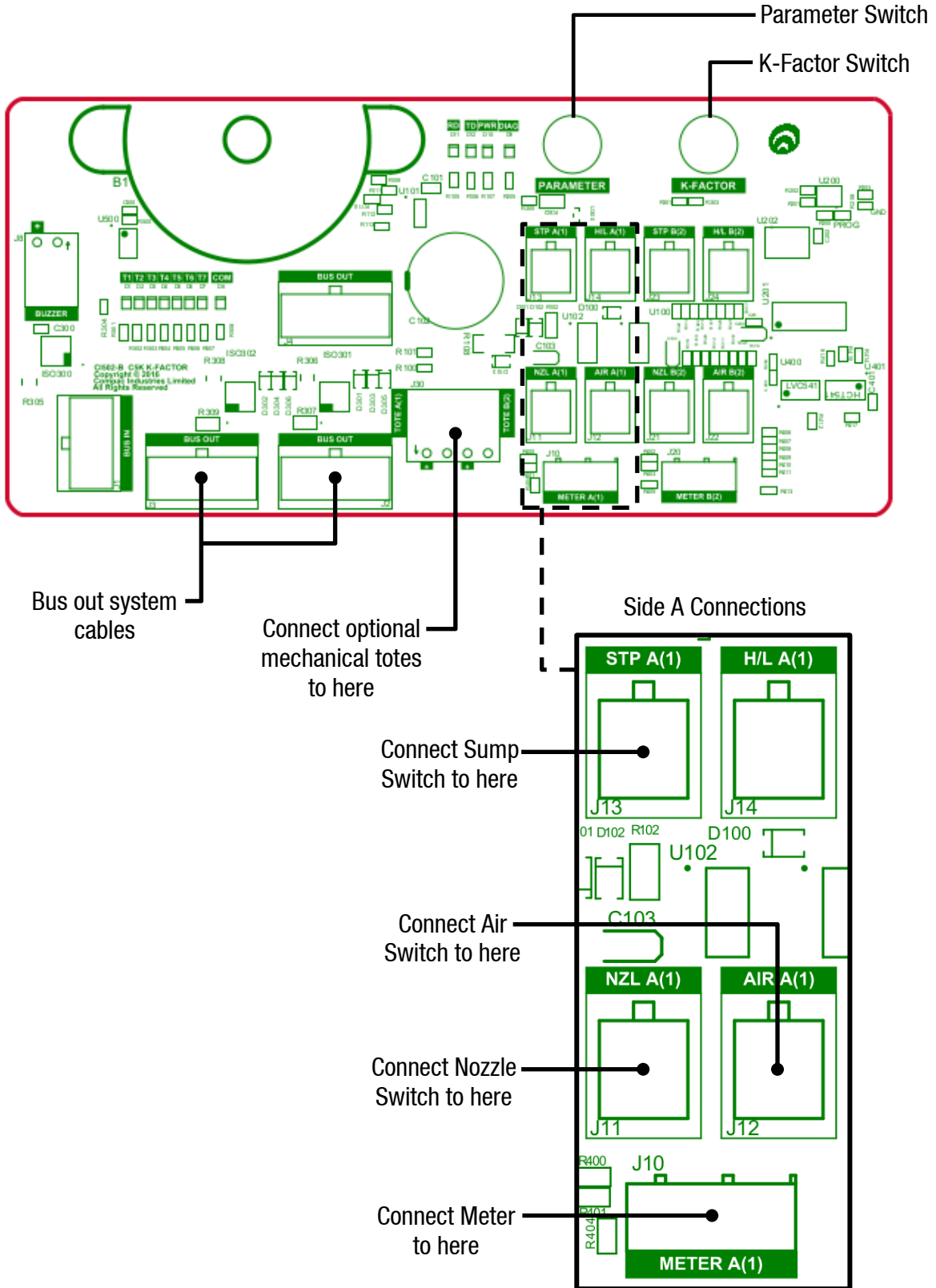

Terminal Board Connections

When using the C5000 electronics for dispenser applications, as well as connecting the incoming mains, the external pump contactors will have to be connected to the terminal board.

Connect External Pump Contactors to:

Side A - Adblue = SIDE A - MTR RELAY (LOW)

Side B – 160LPM Diesel = SIDE B - MTR RELAY (LOW)

Solenoids for side A and B are factory wired as shown below. (L) and (H) refer to low and hi flow respectively.

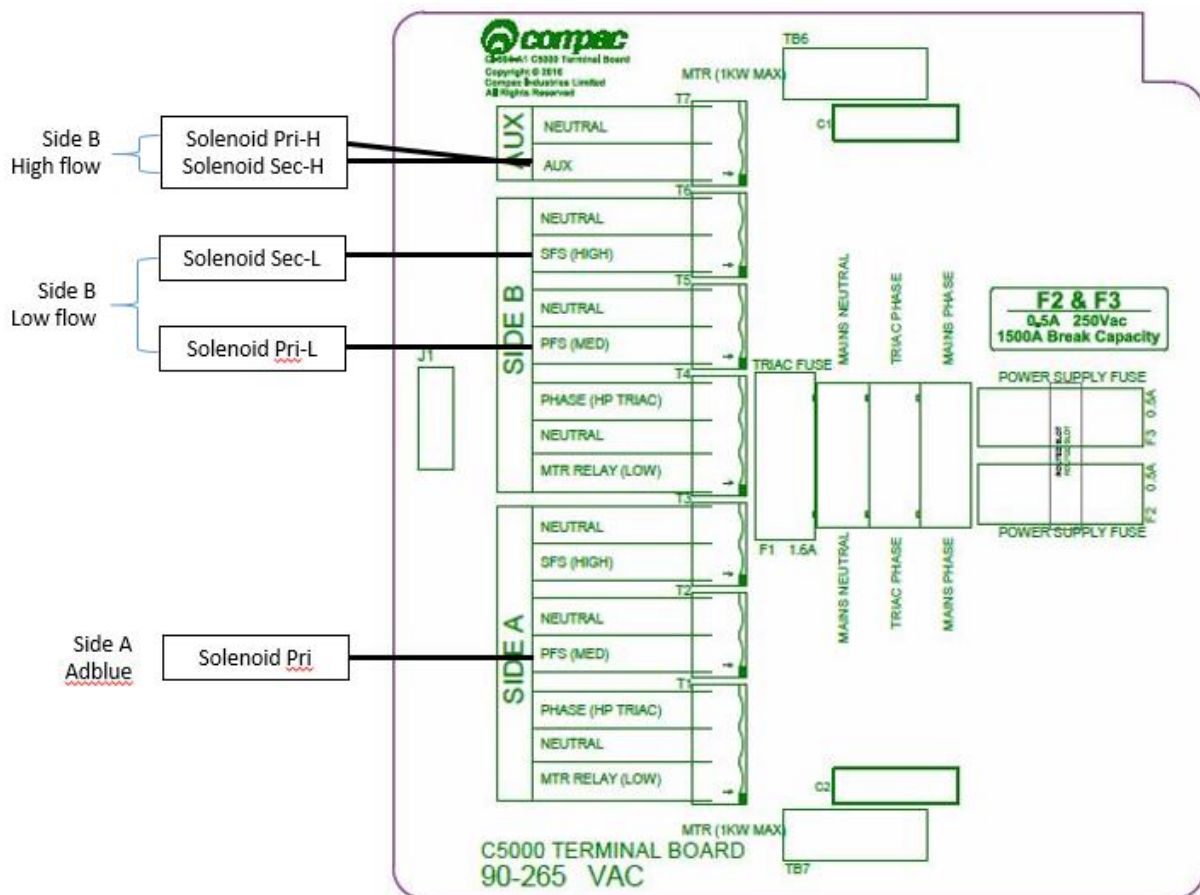

Setting up the C5000

K-Factor Settings

The settings that can be accessed from the K-Factor switch are shown below. Not all of these will need to be changed during installation, therefore information on the following pages refers only to the settings that must be changed. Once the pump has been installed, if further customisation of the unit is desired, refer to the C5000 Manual.

Setting	Price display	Litres display
Dispenser settings. These are set in the factory and should not be changed.	C - A or C - B	*****
Maximum flow		9A **** or 9B ****
K-Factor	FA or FB	*****
Configuration code. This is set at the factory and should not be changed.	C	*****
Solenoid delay		5dA *** or 5dB ***
Preset cutoff. This is available if a secondary solenoid is wired in.		PcA *** or PcB ***
Preset rounding		PrLA*** or PrLb*** PrHA*** or PrHb***
Flow time out		n - A *** or n - B ***

Changing the K-Factor

The K-Factor is used to calibrate product flow. It is a ratio of litres dispensed per revolution of the meter. The K-Factor may need to be calibrated after periods of time. To calibrate the pump, dispense fuel into a certified measuring container and compare the display value with the one dispensed.

Example:

Display shows 10.00 True volume 20.00

To calculate the correct K-Factor from the information above; firstly, record the existing K-Factor.

$$\text{New K Factor} = \text{Existing K Factor} * \frac{\text{Dispensed Amount}}{\text{Displayed Amount}}$$

$$= \text{Existing K Factor} * \frac{20}{10}$$

$$= \text{Existing K Factor} * 2$$

To change the K-Factor, depress the K-Factor switch repeatedly until the following display is shown. To increment a digit, press and hold the parameter switch when the desired digit is flashing. Repeat this procedure for side B if applicable.



Submersible Delay (Sd)

This is the time delay from when the submersible pump starts to when the solenoids in the dispenser open to allow time for the leak detector to reset.

This is factory set by Compac at 005 (five seconds).

If problems are experienced with the leak detector tripping, firstly check that the solenoid delay is still set and then, if necessary, make it longer as follows.

To change the solenoid delay, depress the K-Factor switch repeatedly until the following display is shown. To increment a digit, press and hold the parameter switch when the desired digit is flashing. Repeat this procedure for side B if applicable.



Parameter Settings

The settings that can be accessed from the parameter switch are shown below. Not all of these will need to be changed during installation, therefore information on the following pages refers only to the settings that must be changed. Once the pump has been installed, if further customisation of the unit is desired, refer to the C5000 Manual.

Setting	Price Display	Litres Display
Software Version – the pump will then run a segment test	P*****	P*****
Pump Number		PnA *** or Pnb ***
Price		PA***** or Pb*****
Pump Settings		bA **** or bb ****
High-flow cut off		LFA ***
Low-flow cut off		HFA ***
b Setting. This is not currently in use and should not be changed		b ****
Electronic Totes	LA **** or dA **** Lb **** or dB ****	L ***** d *****

Changing the Pump Number

If the parameter switch is continually depressed, the following menu to change the pump number will appear. Each side must be numbered between 1-99. Entering a pump number 0 will disable the pump.

To change the pump number, depress the parameter switch repeatedly until the following display is shown. To increment a digit, press and hold the parameter switch when the desired



digit is flashing. Repeat this procedure for side B if applicable.

Changing the Price

The price must be set before the dispenser can be used, otherwise an error will be returned. Set the price in dollars per litre.

To change the price, depress the parameter switch repeatedly until the following display is shown. To increment a digit, press and hold the parameter switch when the desired digit is flashing. Repeat this procedure for side B if applicable.



Standalone Mode

In standalone operation, the dispenser will continue working when not connected to a controller. When in Standalone mode no authorisation of fills is required and so fills are simply initiated by removing the refuelling assembly from its holder. If standalone operation is inhibited, the dispenser will not work in standalone mode, regardless of whether the dispenser is ONLINE to a controller or not.

The dispenser ceases to work in standalone mode if connected to a controller, regardless of the position of standalone setting.

Generally, on retail forecourts the dispenser should be set-up for standalone operation. Hence, if the forecourt controller breaks down the dispensers can be set to work in standalone mode simply by turning them off then on again.

For unattended refuelling sites, the dispensers should not be able to work in standalone mode in the event of a controller failure. Therefore, the dispenser should be set-up to inhibit standalone operation.

This is set in the b code on the K factor switch. The b code to run Standalone without Dispenser Controller is 1000. The b code to inhibit Standalone is 0000.



AdBlue Instructions

Cleaning the AdBlue Nozzle

If AdBlue evaporates it may form crystals around the dispenser nozzle. A build up of crystals can block the air passage causing the nozzle to continuously trip off.

If this occurs, rinsing the nozzle in a bucket of warm water will dissolve the crystals and unblock the air passage.

To avoid contamination of the AdBlue, thoroughly dry the nozzle after rinsing, or rinse with AdBlue.

ZVA AdBlue Nozzle

The ZVA AdBlue nozzle with a magnetic safety catch is commonly used on AdBlue dispensers. The following image is included for reference. For further information refer to ZVA direct.

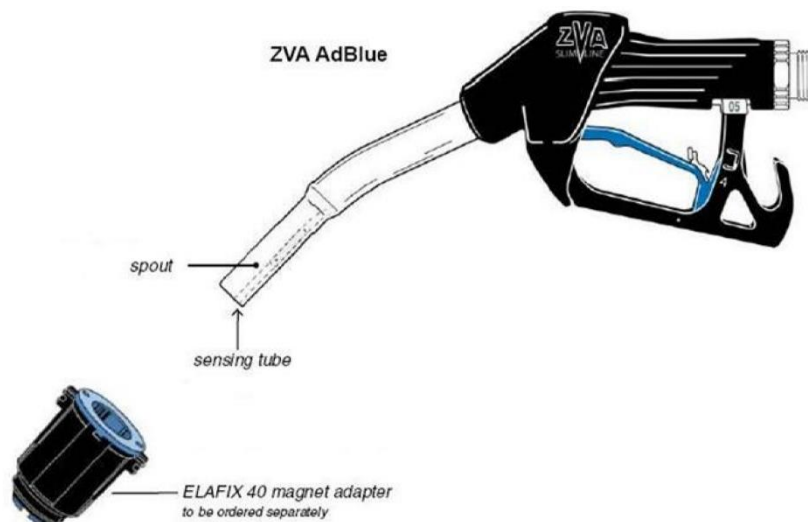

Flow rate up to 40 l/min, working pressure 0,5 – 3,5 bar.

To avoid misfuelling, the standard type of ZVA AdBlue is equipped with a magnet opening in the spout. The nozzle will only open in combination with the magnet adapter ELAFIX 40 which must be installed in the AdBlue filler neck. For the refuelling of other containers or canisters please push an ELAFIX 40 over the spout.

Notes

Pump Controller

If the pump is connected to a controller, check that pump data and transaction information is being correctly uploaded to it. Refer to the controller manual for specific instructions regarding connection and setup.

Spare Fuses

In the event of a fuse blowing on the C5000 Power supply a bag of 3 is included in each flameproof box. Any fuses used from this bag should be replaced.

NOTE: *There are three different ratings used. If replacing a fuse, ensure that the correct value is used.*

Precautions if Using Generator Power

The power output from onsite generators can cause power spikes that may damage electrical components within the cabinet. When connecting to sites powered by generators, please take the following precautions:

1. Install a power conditioner. Although generators are fitted with power regulators, most are not filtered sufficiently for powering sensitive electrical components. We recommend installing a commercial power conditioner and/or UPS between the generator and the unit.
2. Before starting a generator, make sure the power to the unit is turned off. Start the generator, let the generator reach stable operating speed and wait 30 seconds before reconnecting the power to the unit.
3. For units where the generator starts and stops on demand, install a delay timer or PLC to automatically isolate the unit until the operating speed and consistent power output is achieved.
4. Isolate the unit before shutting down the generator.

Error Messages

The unit will have error codes programmed in. The following is a list of error codes and how to rectify these errors.

Error Code	Fault	Action/Information
Er FL0	Excess flow	Maximum flow rate exceeded
Er dEn	Density out of range Temperature out of range	Calibrate meter density using the K-Factor switch Calibrate meter temperature using the K-Factor switch
Er PrSt	The preset entered is below the MMQ	Enter a preset above (or equal to) the MMQ
Er 3	No price	Set the price
Er 8	Reverse flow	Check product is not flowing back into the tank once the delivery has finished. This only occurs if the non-return valves installed on site are faulty
Er 10	Configuration lost	Reconfigure the unit
Er 13	Slave display restarted	Power Failure, Hardware failure
Er 14	K-Factor board offline	Check the connecting bus cable
Er 15	K-Factor board restarted	Power Failure, Hardware failure
Er 3 1	Transaction ended but fuel is still flowing	Solenoid leaking
Er 4 1	Pump comms lost	Check the connecting wire connections to the comms boards from the pump side and from the controller side
Er 50	Meter communication error	Check that the meter is connected correctly. Check correct configuration and correct software installed. Ensure the meter IDs on the dispenser software and V50 meter match
Er 52	Meter error	If the problem persists, repower the unit. Replace the meter if necessary
Er 53	Meter stopped vibrating	If the problem persists, repower the unit. Replace the meter if necessary
Er 54	Temperature sensor failure	If the problem persists, repower the unit. Replace the meter if necessary
Er 55	Meter not ready	Wait for meter to calibrate. If the problem persists, repower the unit
Er 6 1	V50 meter could not set it's zero point	Try restarting the meter. If the problem persists, Replace the meter.
Er 62	V50 meter could not reset the batch (Could not zero the transaction values when nozzle was lifted to start a new transaction)	Try restarting the meter. If the problem persists, Replace the meter.

Er71	V50 meter is set but variant is not selected	Set variant to DEF
Abd	Slave display offline	Check connections to display Check the slave board configurations
hold	Processor offline / no power to processor	This will occur upon start up – allow time for the processor to load. If the problem persists, check connections to processor
cALibc	K-Factor data integrity failure, or the processor board has been replaced	The K-Factor seal must be broken, and the switch must be pressed
cALibP	The K-Factor board has been swapped/replaced	The K-Factor seal must be broken, and the switch must be pressed
cALib	The unit needs calibration, usually due to a hardware change	Check the K-Factor and temperature and density calibrations
cALibF	K-Factor is not set or is 00.0000	Set the K-Factor Calibrate meter
Air	May suggest air is in the system. May be density out of range, or coil amplitude too low while meter is operating, displayed until next sale is started	Make sure pump is running. Check tank and pipework for leaks. Purge system. Increase the Solenoid delay on the K-Factor switch
orun	Overrun – flow above preset	Increase the preset cutoff
SuNP	Sump error – liquid detected in the sump	Empty the sump. Check the dispenser for leaks

Error Messages