



compac

PREMIUM DISPENSER TECHNOLOGY

Laser LPG Installation Manual
Version No: 1.0.7

Model: LPG V50 Dispenser
Date: 10 May 2022



Conditions of Use

- Read this manual completely before working on, or making adjustments to, the Compac equipment
- Compac Industries Limited accepts no liability for personal injury or property damage resulting from working on or adjusting the equipment incorrectly or without authorization.
- Along with any warnings, instructions, and procedures in this manual, you should also observe any other common sense procedures that are generally applicable to equipment of this type.
- Failure to comply with any warnings, instructions, procedures, or any other common sense procedures may result in injury, equipment damage, property damage, or poor performance of the Compac equipment
- The major hazard involved with operating the Compac C4000 processor is electrical shock. This hazard can be avoided if you adhere to the procedures in this manual and exercise all due care.
- Compac Industries Limited accepts no liability for direct, indirect, incidental, special, or consequential damages resulting from failure to follow any warnings, instructions, and procedures in this manual, or any other common sense procedures generally applicable to equipment of this type. The foregoing limitation extends to damages to person or property caused by the Compac C4000 processor, or damages resulting from the inability to use the Compac C4000 processor, including loss of profits, loss of products, loss of power supply, the cost of arranging an alternative power supply, and loss of time, whether incurred by the user or their employees, the installer, the commissioner, a service technician, or any third party.
- Compac Industries Limited reserves the right to change the specifications of its products or the information in this manual without necessarily notifying its users.
- Variations in installation and operating conditions may affect the Compac C4000 processor's performance. Compac Industries Limited has no control over each installation's unique operating environment. Hence, Compac Industries Limited makes no representations or warranties concerning the performance of the Compac C4000 processor under the actual operating conditions prevailing at the installation. A technical expert of your choosing should validate all operating parameters for each application.
- Compac Industries Limited has made every effort to explain all servicing procedures, warnings, and safety precautions as clearly and completely as possible. However, due to the range of operating environments, it is not possible to anticipate every issue that may arise. This manual is intended to provide general guidance. For specific guidance and technical support, contact your authorised Compac supplier, using the contact details in the Product Identification section.
- Only parts supplied by or approved by Compac may be used and no unauthorised modifications to the hardware or software may be made. The use of non-approved parts or modifications will void all warranties and approvals. The use of non-approved parts or modifications may also constitute a safety hazard.
- Information in this manual shall not be deemed a warranty, representation, or guarantee. For warranty provisions applicable to the Compac C4000 processor, please refer to the warranty provided by the supplier.
- Unless otherwise noted, references to brand names, product names, or trademarks constitute the intellectual property of the owner thereof. Subject to your right to use the Compac C4000 processor, Compac does not convey any right, title, or interest in its intellectual property, including and without limitation, its patents, copyrights, and know-how.
- Every effort has been made to ensure the accuracy of this document. However, it may contain technical inaccuracies or typographical errors. Compac Industries Limited assumes no responsibility for and disclaims all liability of such inaccuracies, errors, or omissions in this publication.

Product Identification

Specifications

This manual applies to the installation of LPG dispensers.

Models Covered

NOTE: Do not use this manual for earlier models. Contact Compac for archived manuals if required.

Validity

Compac Industries Limited reserves the right to revise or change product specifications at any time. This publication describes the state of the product at the time of publication and may not reflect the product at all times in the past or in the future.

Manufactured By:	COMPAC INDUSTRIES LTD		
MODEL No:	LASER LL160SQ		
Cert. No:	NMI 5/6A/91B	Date of Manuf:	15/05/15
Serial No:	15D-14133901-02	MMQ:	10L
Max. Inlet pressure: 100 kPa to 350 kPa using an external pump 0 kPa for dispensers with an internal pump			
Environmental Class: C			
Hose #	Product	Flowrate Range L/min	
A1&B1	DIESEL	32-160	
A2&B2	DIESEL	32-160	

Understanding the model number:

The model number for Laser dispensers is split into: Chassis style and hose configuration.

Use the table below to help identify the unit.

Style	Product type	Options
L = single inlet	LPG = LPG	D = Duo two hoses
LL = two inlets		

CAUTION:

Ensure inlet pressure from pumps is within the parameters described on the identification plate.

NOTE: Make sure you use the footprint that relates exactly to your dispenser model and refer to sales order for variations from the standard layout.

Manufactured By:

The Compac LPG dispenser is designed and manufactured by Compac Industries Limited

52 Walls Road, Penrose, Auckland 1061, New Zealand

P.O. Box 12-417, Penrose, Auckland 1641, New Zealand

Phone: + 64 9 579 2094

Fax: + 64 9 579 0635

Email: techsupport@compac.co.nz

www.compac.biz

Copyright ©2015 Compac Industries Limited, All Rights Reserved



Document Control

Document Information	
Document Details	LPQ Installation Template
File Location	G:\Masters\Installation Sheets\Laser
Current Revision Author(s)	Venuka Amarakoon
Authorised By	Emily Sione

Revision History			
Version	Date	Author(s)	Revision Notes
1.0.0	New manual	R Lacey	Amended P-cut setting instructions.
1.0.1	04 Jun 2015	R Lacey	Changed footprint drawings to show drain.
1.0.2	27 Aug 2015	R Lacey	Added Line Delay information
1.0.3	8 Dec 2017	J Jang	New Template
1.0.4	29 May 2018	S Laycock	Added PN3 LPG footprints
1.0.5	07 Dec 2018	R Liu	Updated Contact Information
1.0.6	01 Sep	V amarakoon	Added V2 LPG MF footprints
1.0.7	10 May	T Watt	Updated Laser Footprints

Document Control

Contents

Footprints	2
LASER L-LPG-MF Single Dispenser	2
LASER L-LPGD-MF Duo Dispenser.....	3
MASTER MR-LPGD-MF Duo Dispenser	4
Installation	5
Static Electricity	5
Equipment Required.....	5
Pre-Installation Check	6
Mechanical Installation	6
LPG Pumps	7
Preparing Pipework	7
Mechanical Installation	8
Additional Instructions for Australia	8
Electrical	9
Comms Connections	10
Triac Dip Switches	11
Hoses and Nozzles	12
Breakaways.....	12
Setting up the C4000	13
Configuration Code	13
Parameter Switch Settings	14
K Factor Switch Settings	17
Sealing the K Factor Switch.....	25
Notes	26
Spare Fuses.....	26
Precautions if Using Generator Power	26
Error Messages	27

Footprints

NOTE: Hose fittings are 1/2" female NPT.

LASER L-LPG-MF Single Dispenser

Footprints

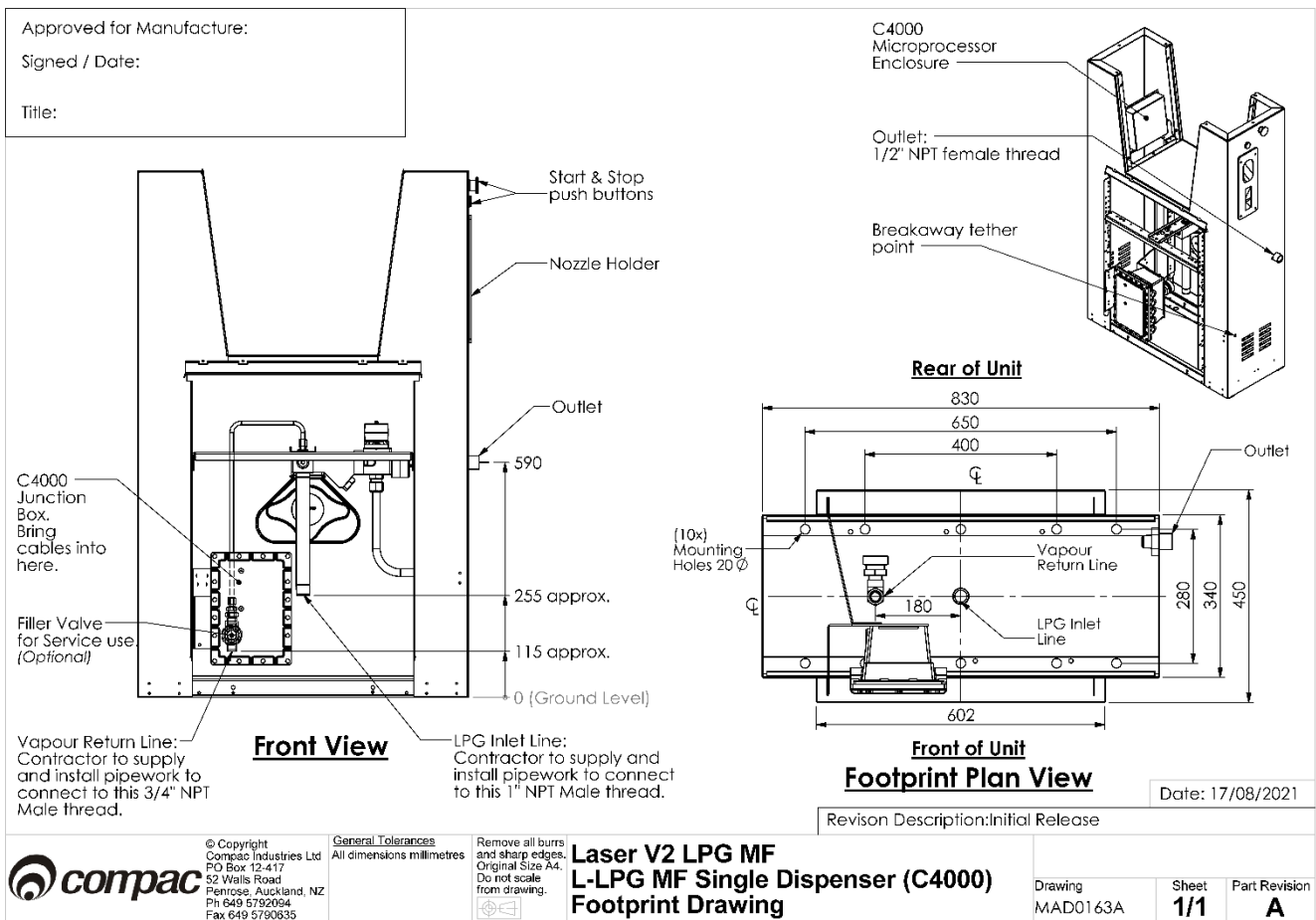

LASER L-LPGD-MF Duo Dispenser

NOTE: LL-LPGD (Dual) dispenser has an identical footprint but the nozzle holders are mounted on the ends of the dispenser

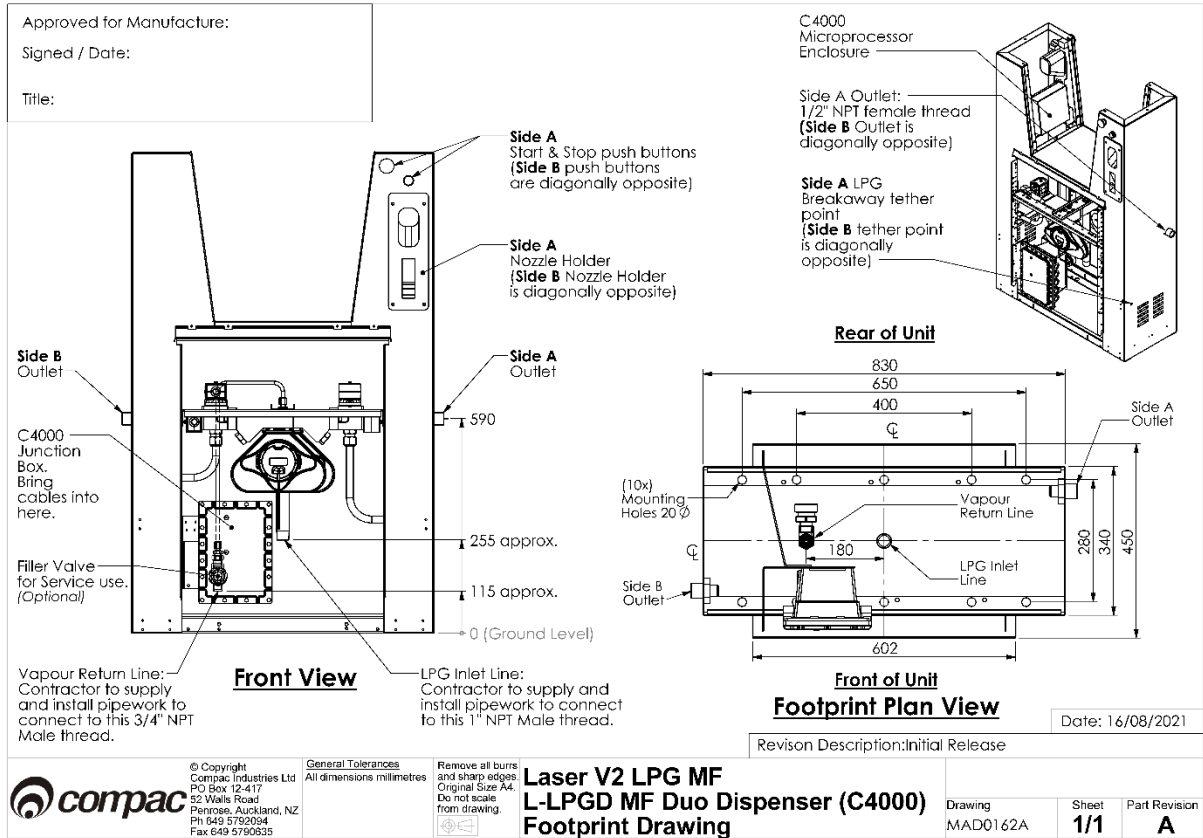

MASTER MR-LPGD-MF Duo Dispenser

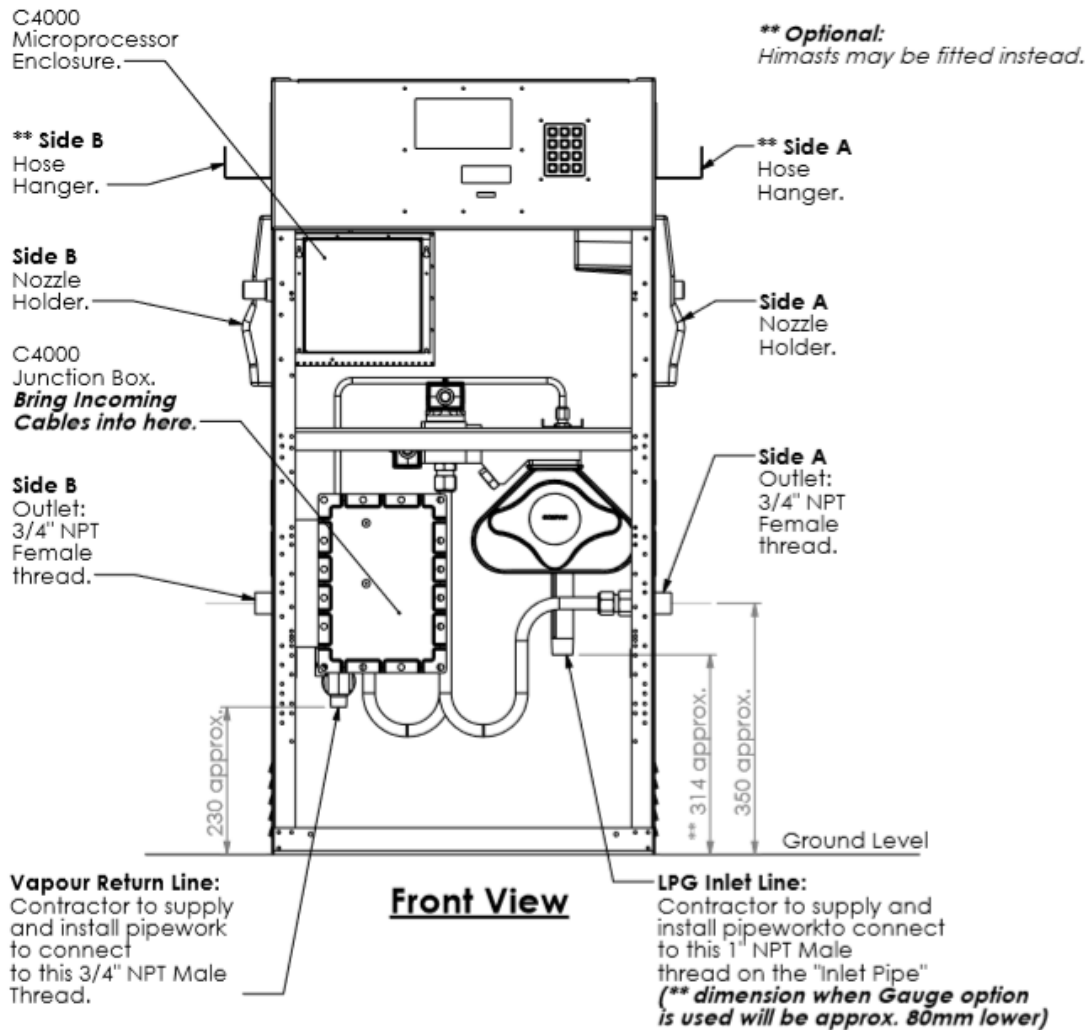

Front View

Rear of Unit

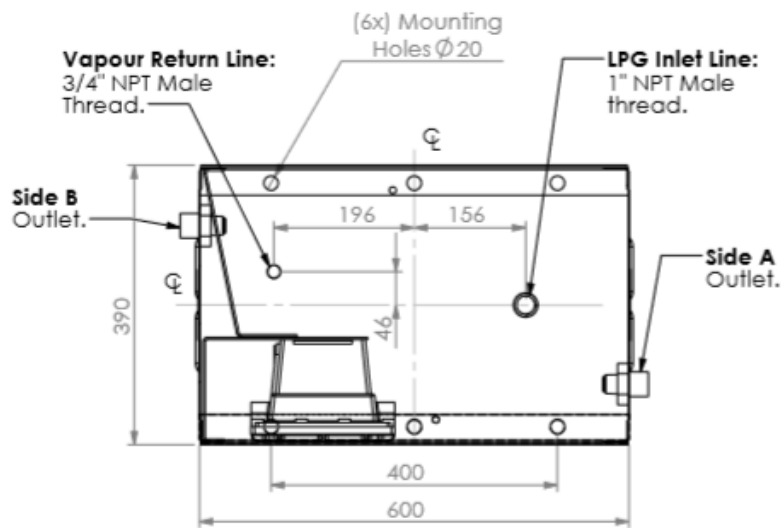

Front of Unit

Footprint Plan View

Installation

Ensure you have the correct qualifications or certification to undertake the work required.

Installation should be in accordance with local regulations.

The dispensing equipment shall be installed to prevent the delivery hose from contacting the ground when not in use.

Where local regulations require a sump to be fitted:

- Sumps must be provided at all dispenser installations with secondary containment pipework and at all new installations; and
- At all sites with sumps, dispensers should be installed with a liquid level detection device fitted in the sump that will raise an alarm if liquid is detected in the base of the sump.

Static Electricity

Electronic components used are sensitive to static. Please take anti-static precautions.

An anti-static wrist strap should be worn and connected correctly when working on any electronic equipment. If an anti-static wrist strap is unavailable, or in an emergency, hold onto an earthed part of the dispenser frame whilst working on the equipment. This is not a recommended alternative to wearing an anti-static wrist strap.

NOTE: *Compac Industries Limited reserves the right to refuse to accept any circuit boards returned, if proper anti-static precautions have not been taken.*

Equipment Required

To complete a successful installation and setup you will require the following equipment:

Tools to install pipework if pipework not already in place:

- Tools to mount the dispenser
- Tools to install the wiring
- An LPG densitometer/temperature gauge and compensation tables or,
- An LPG master calibration meter.

Pre-Installation Check

Once the dispenser is received on site, check that no damage has occurred while in transit – in particular, damage to electronics due to vibration or jarring. All terminals and plugs should be checked, including IC chips, to ensure they are securely in place.

Mechanical Installation

The following guidelines for mechanical installation should not override local regulations.

Site Plumbing

LPG companies have their own requirements with regard to the inlet piping to a LPG dispenser. Compac's primary requirements are:

- A liquid feed line of sufficient size able to deliver 80lpm to a dispenser. This line size is typically 25mm ID schedule 40 steel pipe.
- The Pump is required to give a minimum pressure differential (above the vapour pressure) of 700 kPa at the flow rate required.
- A vapour return line without restriction back to the LPG tank capable of flowing 80lpm of vapour with a pressure drop of less than 10kPa. This line size is typically 20mm ID schedule 40 steel pipe.

Air Actuated Ball Valves

Air Actuated Ball Valves are often used directly under or near the base of the LPG dispenser. If the air supply is cut and vented, the valves shut off automatically.

A pneumatic, three way emergency shut off valve can be located on the dispenser or nearby.

Often a glass tube is attached to the dispenser and the ground. If the dispenser is hit, the glass shears and cuts the air supply to the air actuated valves.

When Compac supplies the air actuated valves, they have ASA300 flanges to match the inlet flanges of the dispenser so they can be bolted directly to our inlet pipework.

Shear Valves

Some companies use shear valves under the dispenser. If the dispenser is hit and the valves shear they cut the supply of LPG to the dispenser. The Fischer ISC Valve model C407-10-05 is typically used. Caution must be taken when installing these valves so that they can open fully when screwed into the pipework. We have experienced cases where the vapour return line has been blocked by incorrect installation.

Excess Flow Valves

Some companies require an excess flow valve to be installed in the liquid feed line just before the dispenser.

LPG Pumps

If an external LPG pump is used instead of a submersible pump, the pump relief valve must not be piped into the saturated liquid/vapour return line. It must have its own line to the tank. There must be no restrictions in the vapour return line back to the tank that can cause back pressure.

Pump Requirements

The Pump is required to give a minimum pressure differential (above the vapour pressure) of 700 kPa at the flow rate required. If this is not achieved, then very low or no flow may result.

Before connecting the pipework to the LPG dispenser please follow the correct procedure for making sure there is no dirt, rust or water in the pipework.

Preparing Pipework

Prepare a pig consisting of a foam pad with an abrasive pad on the front.

Blast the pig along the pipework at least three times using high pressure Nitrogen.

Flush the lines with methanol. Take care to make sure the methanol is fresh and has not absorbed water. Be very careful handling the methanol as it is very poisonous and is absorbed into the bloodstream with direct contact.

Blast the lines clear with high pressure Nitrogen until the gaseous nitrogen expelling from the end of the pipe is clear of methanol and particles.

It is critical the LPG Liquid feed pipework and the vapour return pipework is cleaned and flushed of any dirt, rust scale or other impurities. Dirt can cause the hydraulic components to malfunction.

Malfunction or damage to the hydraulics of the LPG dispenser caused by dirt, water or rust is not covered by warranty. The pipework needs to be purged of air and vapour up to the valve under the dispenser before the dispenser is charged with product. This is to avoid having an explosive mixture in the dispenser.

Mechanical Installation

Secure dispenser with at least four (4) 16mm studs or masonry anchors.

Prior to connecting the inlet and vapour return pipework flush the lines thoroughly to remove any sand, dirt, rust or scale.

Connect the inlet and vapour return lines to the ASA300 flanges on the Compac LPG Dispenser.

All meters within the dispenser must be calibrated on site before use by the public. Calibration is the responsibility of the installer.

NOTE: *Faults caused by sand, dirt, rust or scale are not covered by warranty.*

Additional Instructions for Australia

It is the responsibility of the installer to ensure that all local regulations are complied with. The instructions listed here are a guide only.

Additional requirements for Australian installations include:

All meters within must be calibrated on site before use by the public. Calibration is the responsibility of the installer.

An excess flow valve, rated in accordance with AS1596, shall be fitted in the liquid inlet pipe entering the cabinet and shall be as close to the ground level as possible.

A remote shutdown system shall be fitted. Refer to AS/NZS 1596:1997 section 9 for details.

NOTE: *The overspeed sensor ('T10' terminal in the flameproof box) must be connected so that if there is an abnormal flow of fuel it will stop the remote pump and cause the tank's liquid outlet internal control valve to close.*

Electrical

The instructions below refer to basic installation wiring. For full wiring specifications refer to drawing AP375 available on the Resources section of the Compac website.

Prior to dispenser installation ensure that there is at least a two-metre tail on the incoming underground mains supply / pump contactor cable and comms cable (if comms enabled). These cables are terminated at the C4000 power supply, which is housed in the flameproof enclosure located in the bottom of the dispenser, behind the door.

Mains power wiring should be rated for a maximum current draw of 10 A rms at 220-240 V ac.

Refer to AS/NZS 60079.14 for appropriate cabling.

When replacing the lid of the flameproof enclosure, ensure the sealing O ring is in place.

NOTE: All cables entering the power supply must be glanded with approved 20mm flameproof glands.

NOTE: Output to submersible pump(s) is 230 V ac, 300 mA max. It is wired to the pump contactor/relay at the switchboard and not directly to the pump.

NOTE: Excess flow output is 230 V ac, 300 mA max.

NOTE: Dispenser comm's connect to dispenser controller such as DCA, Communicator Controller etc. (option). Comms cable is not intrinsically safe.

WARNING:

Fully replace the lid of the power supply before starting the dispenser.

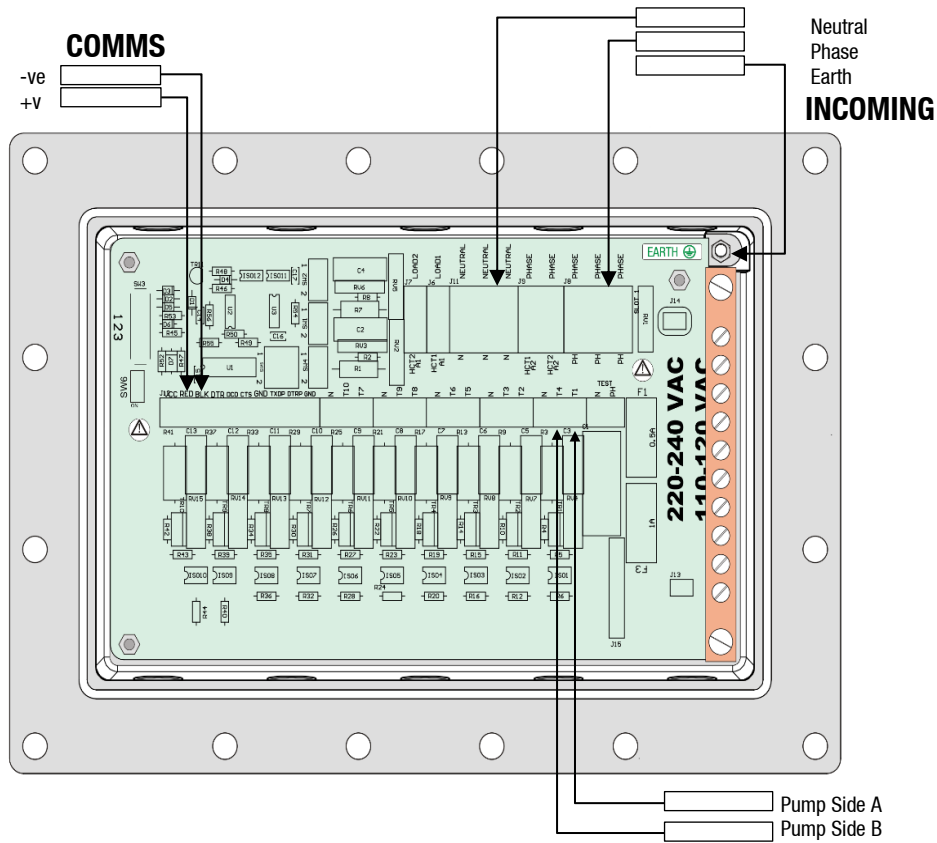

Comms Connections

Dispensers can communicate via standard Compac, Gilbarco or RS485 protocols. The protocol is set at the factory. Connections are made to terminals marked RED and BLK. If experiencing problems, try swapping the wires in the terminals and check the position of the comm's switch.

Switch SW3 position determines the protocol:

SW3	Comms Protocol
1	Compac
2	Gilbarco
3	RS485

NOTE: The dispenser will be set to the protocol specified when the unit was ordered, to change communication protocols from the factory setting, a software change is also required.

Triac Dip Switches

IMPORTANT NOTE:

Great care should be taken not to accidentally change the setting of these switches while working in the Flame-proof box. Operating the unit with these incorrectly set can result in damage to the C4000 Power Supply or incorrect operation of the triacs.

These switches are set in the factory and should not be changed.

If they are accidentally changed these are the correct settings for Laser Dispenser applications. They are 3 position switches.

Switch	Position
SW1	2
SW2	2
SW4	2

Hoses and Nozzles

The unit may or may not be supplied with dispensing hose and nozzle assemblies.

If customer supplied hoses or hose assemblies are used they must comply with AS/NZS 1869 Class C, D or E or UL21 and shall incorporate a breakaway.

LPG hose break devices must comply with AS/NZS 1596.

Breakaways

Ensure the breakaway is installed between the nozzle and the high-mast or pylon (if fitted). Any breakaways that have been subject to a break-away situation should be inspected and refitted or replaced in accordance with the original manufacturer's instructions.

Setting up the C4000

Once the dispenser is connected on site, the final setup check and calibration to complete the installation must be carried out, using the Parameter Switch and Calibration (K-Factor) Switch.

These switches are found on the C4000 Microprocessor Board which is housed in a metal enclosure located behind one of the inner column panels.

Configuration Code

The configuration code has been set at Compac and should not be changed.

In the event of it being lost and having to be re-entered the configuration is written on the yellow label on the C4000 processor board cover.

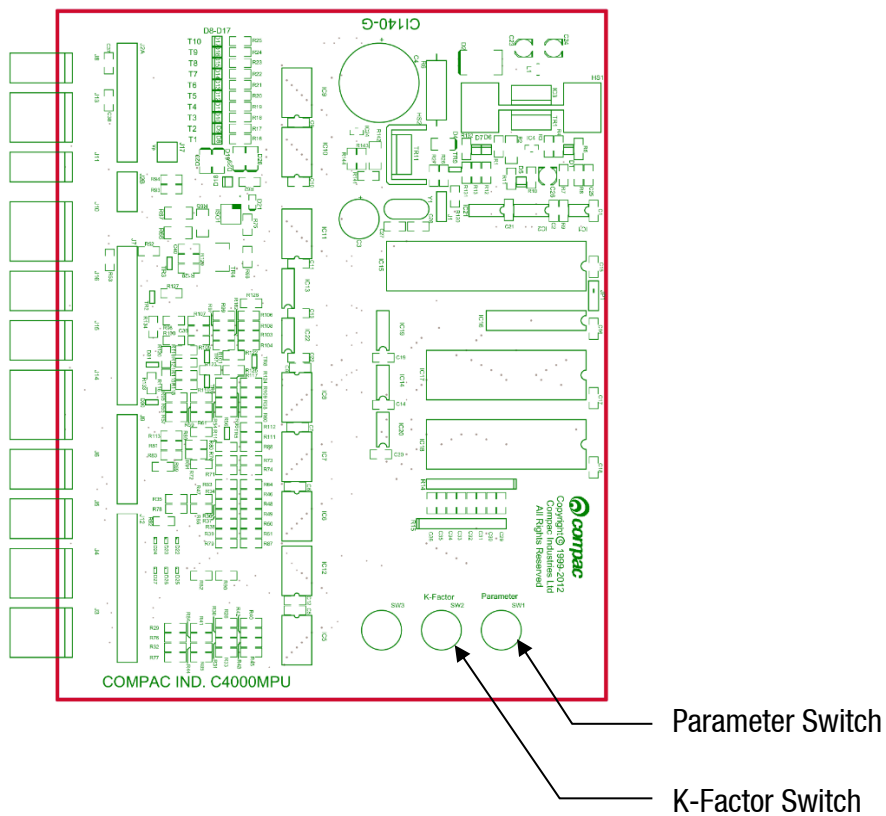

Parameter Switch Settings

The parameter switch is used to set the following parameters:

- The price per litre (for standalone dispensers) P_r for single hose dispensers $P_r A P_r b$ for two hose dispensers.
- The b configuration code (turns temperature compensation on and off on LPG dispensers and inhibits standalone operation.)
- Displays the data on the last delivery.
- Hose/pump number P_n (single) $P_n A$ and $P_n b$ (two hose) settings changes the dispenser/pump/hose number.

Pressing and releasing the parameter switch scrolls through the parameter screens and each changeable digit. Holding the switch in will scroll through the digit selected. Releasing the parameter switch for more than ten seconds will return the display to the normal dispensing display.

The Parameter Switch is located on the C4000 board as shown below:

Setting the Price

If the dispenser is a standalone unit and is not connected to a forecourt controller, the price is set using the parameter switch.

Using the Parameter Switch, follow the chart to set the price for the hose(s) in question.

Step	Action	Result
1	Ensure that the nozzle is hung up.	Dispenser in idle state.
2	Press and Hold the Parameter switch until the "Price per litre" is displayed.	The price for side 'A' is shown as $P****$ on the litres display and $P_r A$ is displayed on the money display.
3	Press and hold the Parameter switch.	A digit, of the displayed 'Price per litre', will begin to increment.
4	When the digit is correct, release the Parameter switch.	

Setting up the C4000

5	Repeat steps 3 and 4 for each digit of the 'Price per litre'.	NOTE: The C4000 will reset itself if the Parameter switch is left for more than around 10 seconds.
Continue for Dual hose units		
6	Press and release the Parameter switch 8 or more times in quick succession.	The price for side 'B' is shown as P**** on the litres display and P _r b is displayed on the money display.
7	Repeat steps 3 to 5 above.	

Setting the Dispenser Number

This must be set at the dispenser for each hose, so that communications with a controller can take place. The location of this switch is shown in the diagram below.

Depress the Parameter Switch nine (9) or more times until the message **PnA**** appears in the litres display window. When the switch is pressed again **Pnb**** will appear on the display. These two options will toggle each time the switch is pressed. To alter either of the dispenser numbers, press and hold the Parameter Switch when the dispenser number to be altered appears on the display. This number will then increment. The switch should be released when the desired dispenser number is displayed. The value of the displayed number will then be stored in the C4000 memory as the dispenser number for that hose.

NOTE: For a single hose only **Pn** will appear.

b Configuration Settings

Temperature Compensation Off/On:

To allow for calibration with the temperature compensation turned off, use the parameter switch to change the last digit of the b configuration code to 1 (***) 1). The display will read **EESE** while in this mode. When finished calibration, return the digit to 0.

Standalone Operation:

In standalone operation, the dispenser will continue working when not connected to a site controller. 'Stand-alone' mode requires no authorisation and a fill is initiated by removing the nozzle from its holder. If standalone operation is inhibited, the dispenser must receive authorisation from a controller in order to work.

Generally on retail forecourts the dispenser should be set-up for standalone operation. If the site controller breaks down the dispensers can be set to work in 'stand-alone' mode simply by turning them off then on again. In 'stand-alone' operation, if the controller comes on-line, it will automatically resume controlling the dispenser.

For unattended refuelling sites, the dispensers should be set up to inhibit standalone operation in the event of a controller failure.

This is set in the 'b' code on the K factor switch.

The 'b' code to run 'stand-alone' without Dispenser Controller is **0*****.

The 'b' code to inhibit 'stand-alone' is **1*****.

K Factor Switch Settings

K-Factor and other various configuration settings are set using the K-Factor switch on the C4000 board. The K-Factor switch controls the following functions:

- Meter identification number **1d-A** or **1d-b**
- Meter temperature **E-A** or **E-b**
- Density at 15°C **d 15-A** or **d 15-b** (actual meter reading shown in \$/litre window)
- Meter calibration factor **F-A** or **F-b**
- Solenoid delay **5d** delays starting of dispenser until supply pump has started.
- Preset cut-off **P-cut** Slows fuel delivery before preset amount is reached.
- C Configuration code **c 0005** | for single hose **00052** for two hose

Many of the functions have been set at the factory and will not require changing. These instructions only refer to the functions required to set up the dispenser.

Calibrating the Temperature

Before calibrating the meter (K-Factor), the meter temperature gauge must be calibrated.

Method:

Fill the thermowell on the top of the inlet manifold with glycol and place a thermometer probe into it .

- Run fuel through the meter to balance the temperature of the meter and thermowell and take a temperature reading.
- Using the K-Factor switch, scroll through until the top line of the display reads E-A. The line below shows the compensated temperature reading and the \$/Litre display shows the temperature the meter is reading.
- Use the K-Factor switch to change the compensated temperature to match the reading of your temperature probe.
- For a two hose model, perform the same operation for side B.

Calibrating the Density Offset

Before calibrating the meter (K-Factor), the density offset must also be calculated and set.

Method:

Use a hydrometer to take the density and temperature of the LPG.

- Use the density tables to calculate the density at 15°C
- Using the K-Factor switch, scroll through until the top line of the display reads d15=A. The line below shows the compensated density reading and the \$/Litre display shows the density the meter is reading.
- Use the K-Factor switch to change the displayed compensated density to match the actual compensated density of the LPG sample.
- For a two hose model, perform the same operation for side B.

Calibrating the Meter (K-Factor)

The calibration factor for the meter is adjusted by using the K Factor Switch. The calibration factor is a proportional factor of calculated litres dispensed compared to actual litres dispensed. A calibration factor must be set for each meter in the dispenser.

There are two common methods of calibrating the LPG dispenser:

- Gravimetrically [by weight] with the temperature compensation turned ON.
- By Master Meter with the temperature compensation turned OFF.

The most accurate method is Gravimetrically with the temperature compensation turned ON. The easiest method is by Master Meter with the temperature compensation turned OFF. The two methods of calibration are described as follows:

Calibration Using Gravimetric Method with Temperature Compensation Turned ON

Method:

- Make sure the meter temperature is calibrated correctly.
- Using a hydrometer, take the temperature and density reading of the LPG. Use the density compensation tables to convert the density to 15°C.
- Using the K-Factor switch, check that the density offset figure matches the converted density figure. Change the offset if needed.
- Using the Parameter switch, scroll through to the b setting and check that the temperature compensation is turned **ON**. The configuration code should be **b-0000**.
- Make a few deliveries so the temperature of the LPG in the dispenser is at tank temperature and to make sure there is no vapour in the system.
- Put an empty test bottle on the scale and zero the scale or record the bottle weight.
- Remove the nozzle from the nozzle holder and screw it into the bottle and open the valve on the tank only. Do not open the LPG nozzle.
- Press the start button.
- Wait for the displays on the dispenser to go through its **888888**s and return to **0.00**.
- Open the nozzle valve.
- When dispenser has reached around 20 litres turn the nozzle valve off.
- Turn off the tank valve and unscrew the nozzle valve from the tank and hang up the nozzle.
- Record the weight of the tank and the litres delivered on the dispenser
- Divide the weight of the LPG delivered by the density factor @ 15°C (Volume dispensed) and compare this with the displayed Litres delivered. If the calibration is out adjust the K Factor using the following formula:

$$\text{New K Factor} = \text{Existing K Factor} * \frac{\text{Volume dispensed}}{\text{Volume displayed}}$$

To Increase or Decrease the K-Factor Setting

- Hang up the LPG nozzle after doing a test fill.
- Press the K factor switch once and release. The display will show **F***** if the dispenser is a single and **FA****** if the dispenser is a dual. **** is the default factory K-Factor setting for LPG.
- Press the K-Factor switch until you reach the digit you want to change and hold the K-Factor switch in to scroll. When the correct digit is reached release the switch.
- Press and hold the switch again and the next digit will scroll. When the correct number is reached release the switch.
- Continue this procedure until the correct K-Factor is entered.
- Do another fill to check the calibration.

For a dual LPG dispenser, after calibrating side A do a calibration fill on side B.

To change the calibration factor for the B side, press the K factor switch 8 or more times until **Fb****** appears.

Repeat steps 3 – 6 to change the K-Factor for side B.

When the K Factor switch has been set up it should be sealed using the supplied plastic cover wired to the C4000 microprocessor board to prevent unauthorised changes.

Example:

- Take a density and temperature reading of the LPG using a LPG hydrometer.

$$\text{Temperature} = 18^{\circ}\text{C}, \text{Density at } 18^{\circ}\text{C} = 540 \frac{\text{kg}}{\text{m}^3}$$

- Correct the density at the observed temperature to density at 15°C using the tables in the Service Manual and enter the density at 15°C into the C4000.

$$\text{Density at } 15^{\circ}\text{C} = 544 \frac{\text{kg}}{\text{m}^3}$$

- Weigh a LPG bottle.

$$\text{Initial weight of LPG bottle} = 20\text{kg}$$

- Fill the bottle with LPG. Make sure the display has gone through the **□□□□□** stage and has reset to zero before allowing any LPG to flow into the bottle. The meter encoder count is reset after displaying **□□□□□**. Record the temperature of the fill using a thermometer in the thermo well in the pressure-temperature distribution block.

$$\text{Temperature} = 18^{\circ}\text{C}$$

- Weigh the full bottle.

$$\text{Full bottle weight} = 49\text{kg}.$$

- Calculate the LPG weight that filled the bottle.

$$\text{Weight that filled the bottle} = 49 - 20 = 29\text{kg}.$$

- Divide the weight [kilograms] by the density at 15°C x 1000. This gives you the delivered litres.

$$[Vd] Vd = \frac{29}{544} * 1000 = 53.30.$$

- Record the dispenser-registered litres.

$$[Vr] Vr = 55.05L.$$

- Increase or decrease the calibration K-Factor to make the dispenser displayed litres amount increase or decrease by the proportion of difference.

$$\text{New K Factor} = \text{Existing K Factor} * \frac{Vd}{Vr}$$

$$\text{Original K Factor} = 0.6450$$

$$\text{New K Factor} = 0.6450 * \left(\frac{53.30}{55.05}\right) = 0.6245.$$

NOTE: When calibrating Gravimetrically do not use the preset function (if installed on dispenser). At the end of the fill the preset solenoid shuts the flow of LPG off. At this stage both the nozzle and the tank valve are still opened but the dispenser has shut down. The LPG that is in the hose is then drained into the tank. Since at the start of the fill the hose is full and at the end of the fill the hose is empty the scales will not agree with the dispenser. For subsequent fills using the preset to stop the hose is empty each time and therefore results are repeatable. When filling a car this does not happen as the car cylinder valve generates back pressure and the hose does not drain. When calibrating Gravimetrically always manually shut the fill down using the nozzle valve.

Calibration by Master Meter with the Temperature Compensation Turned OFF

- Set the temperature compensation **OFF**. The b configuration code should be set to **6000** l.
- Connect the dispenser nozzle to the Master Meter. Connect the Master Meter into the Vapour Return line fitting.
- Make a few deliveries back into the main tank so the temperature of the LPG components in the dispenser are at tank temperature and to make sure there is no vapour in the system.
- Make a delivery of 100 litres. Make sure the dispenser goes through the **88888**'s before starting the fill through the master meter. The reason for this is that the dispenser primary solenoid is opened during the **88888**'s to purge the refuelling hose of any accumulated vapour to prevent pre-registration of the meter.
- Compare the reading of the Master Meter [Vd] with that of the dispenser [Vr].

NOTE: If the temperature at the master meter is different to the temperature at the dispenser then that must be corrected using ASTM Table 54. Very approximately: a 1°C temperature difference causes a 0.3% difference in volume.

NOTE: The design of the V50 LPG dispenser means there should be negligible pressure drop between the dispenser and the Master Meter. If regulations or site-specific requirements require a compressibility factor to be included in calculations, compressibility factor tables are included in the V50 service manual.

- Increase or decrease the calibration K-Factor to make the dispenser's displayed litres amount increase or decrease by the proportion of difference.

$$\text{New K Factor} = \text{Existing K Factor} * \frac{Vd}{Vr}$$

Setting the Preset (P-cut)

Prior to the dispenser reaching its preset amount, the solenoids are switched to give a low flow rate to prevent overrunning the preset amount. The “preset cut-off” sets the amount (in litres), prior to the preset amount being reached, at which the solenoids will switch to a low flow rate.

If you are experiencing overruns, use the following calculation to adjust the P-cut figure: [Price per Litre] X [over-run (displayed as a dollar value)] + existing P-cut figure

Example:

Price per Litre = \$1.30

Dollar amount of fuel required = \$20.00

After delivery price display shows: \$20.04 (an over run of \$0.04)

Existing P – cut figure 1.50

*New preset = (1.30 * 0.04) + 1.5 = 1.552*

Round this number to three digits to get your new P – cut = 1.55

NOTE: *If the high flow solenoid is cutting off a long time before the preset figure is reached resulting in slow filling, the P-cut number can be adjusted down until an over run is achieved then the above calculation used to fine tune it.*

Solenoid Delay (Sd)

The Solenoid Delay was installed in the program to enable the "delay" between the remote pump starting and the dispenser solenoids opening.

This setting should never be set more than 4-6 seconds. Its main purpose is to allow the leak detector on the submersible pump to carry out its leak test.

The default setting is **d0000** (i.e., no delay).

Setting the Solenoid Delay:

Use the K-Factor switch to select the **sd** setting. While setting this value, the price display will indicate Sd and the volume display will indicate **d****** where * equals one second.

Line Delay (Ld)

Where LPG pumps are sited some distance from a dispenser, the LPG in the supply line will vaporise over time leading to density errors when the pump is used infrequently. The line delay (Ld) setting delays the opening of the solenoid by up to 99 seconds to allow the pump to bring the LPG supply line up to a pressure that will condense the gas. To prevent long delays when the pump is in frequent use, the software records the time between fills and applies a proportion of the maximum set delay up to a maximum of 8 hours idle time. When there is less time between fills the software proportionally reduces the delay. For example: If the Ld is set to 60 seconds, after 8 or more hours of idle time the delay will be 1 minute, after 4 hours idle time the delay will be 30 seconds, after 2 hours of idle time the delay will be 15 seconds. When the calculated idle time is less than 3 seconds, the line delay is ignored and the dispenser will just do a density check before engaging the solenoids to start a fill. While the dispenser is in line delay mode, the display will read **READY in ****. The '**' value will count down in seconds to the density check.

NOTE: When the pump is repowered, the line delay will be reset to the maximum set Ld value for the first use.

Setting the Line Delay:

If you are experiencing “density” or “gas” errors when the dispenser has been used infrequently, you will need to increase the line delay setting

Use the K-Factor switch to select the Ld setting. While setting this value, the price display will indicate **Ld **** where '*' equals one second.

Finding your optimum setting is a matter of trial and error. If the dispenser is being used frequently during the day and you only get a density or gas error on the first use in the morning, a large Ld setting (60 – 90 seconds) will only hold up the first user of the day but will greatly reduce the chance of an error. If the dispenser is close to the pump and is only used every few hours or depowered between use, the Ld setting can be made smaller or set to zero (factory setting) to minimise the delay before the dispenser starts.

Sealing the K Factor Switch

After calibration the K-factor switch should be sealed as shown:

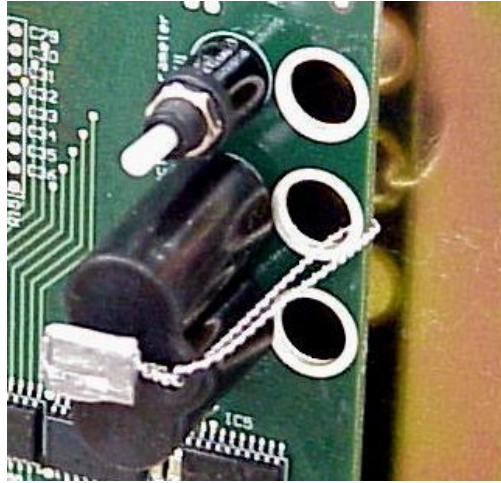

After Commissioning

It is recommended that after the dispenser has been set up, commissioned and calibrated that the strainer be removed from the manifold block and thoroughly cleaned before being replaced.

Notes

Spare Fuses

In the event of a fuse blowing on the C4000 Power supply a bag of 3 is included in each flameproof box. Any fuses used from this bag should be replaced.

NOTE: *There are three different ratings used. If replacing a fuse, ensure that the correct value is used.*

Precautions if Using Generator Power

The power output from onsite generators can cause power spikes that may damage electrical components within the cabinet. When connecting to sites powered by generators, please take the following precautions:

- Install a power conditioner. Although generators are fitted with power regulators, most are not filtered sufficiently for powering sensitive electrical components. We recommend installing a commercial power conditioner and/or UPS between the generator and the unit.
- Starting up. Before starting a generator, make sure the power to the unit is turned off. Start the generator, let the generator reach stable operating speed and wait 30 seconds before reconnecting the power to the unit.
- For units where the generator starts and stops on demand, install a delay timer or PLC to automatically isolate the unit until the operating speed and consistent power output is achieved.
- Isolate the unit before shutting down the generator.

Error Messages

Error Code	Fault	Action
cAL 1b	Meter not paired to dispenser	Pair the meter to the dispenser. See service manual
Err 3	No price or dispenser number set	Set the dispenser number or: Set a price at the dispenser or at the controller
Er FL0	Excess flow	Maximum flow rate exceeded
Err 8	Excess reverse flow	Check product is not flowing back into the tank once the delivery has finished
Err 10	Configuration lost	Reconfigure C4000: refer to C4000 manual
Err 12	C4000 memory failure	Change memory IC
Er 50	Modbus error	Check connections and correct software installed
Er 52	Meter error	Replace meter electronics or complete meter
Er 53	Coil failure	Replace meter
Er 54	Temperature sensor failure	Replace meter electronics
Er 55	Not ready	Wait for meter to calibrate
Er dEn	Density error	Replace meter electronics
GAS	Vapour detected (will display until next sale started)	Check pump pressure to dispenser Check solenoid operation
PEd	Display error	Check display cable for loose wires/crimps
Abd		Replace display PCB