

MAIN DIN RAIL

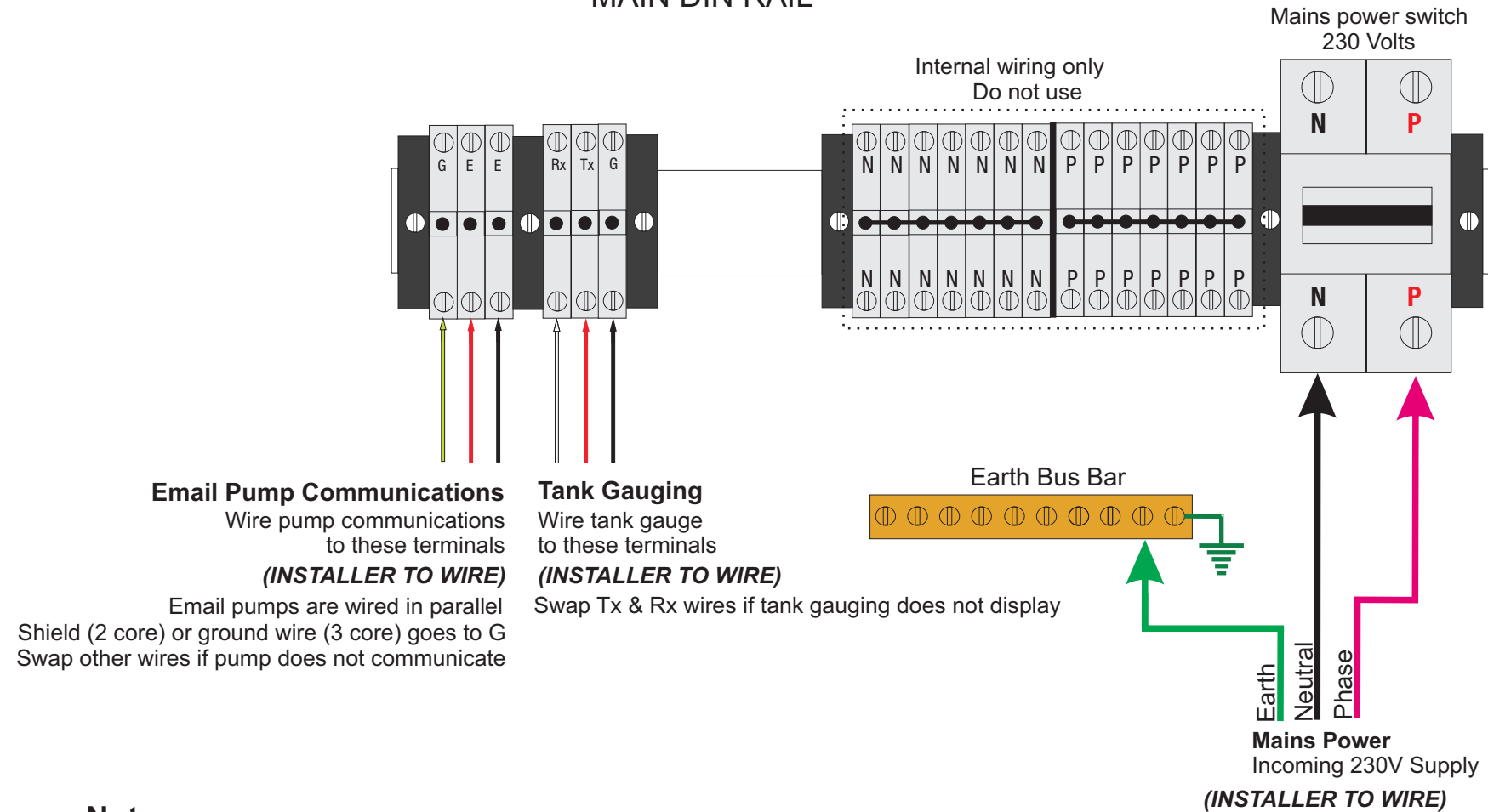

Notes:

- Use appropriately sized cable for the application
- Use appropriate cable for hazardous zones where required
- Do not run communications cables close to power cables
- It is recommended to use ferrules on all communication wires
- Gland all cables that enter the cabinet
- Seal all unused holes in the cabinet
- External aerial cable (option) screws into RF socket on cellular modem
- Always replace electrical covers



DCA INSTALLATION WIRING DIAGRAM Email Pump Connections

REVISION A

DATE : 17 October 2012